**DC****GENERALITÀ / FEATURES**

Elettropompe sommergibili da drenaggio con girante aperta che, oltre ad elevate portate, garantiscono prevalenze eccellenti. Ideali per applicazioni civili ed industriali, sono progettate per uso gravoso. Disponibili per installazione libera e con piede di accoppiamento.

Centrifugal with open impeller drainage pumps that besides high capacity, they guarantee high head. These pumps, ideal for industrial and civil application, are specially designed for heavy use. Available for mobile and permanent installation with coupling foot.

MATERIALI / MATERIALS

- Corpo pompa in ghisa
- Girante in ghisa
- Albero motore in acciaio inox AISI 304
- Doppia tenuta meccanica in carburo di silicio/ceramica carbone, con paraolio lato pompa
- Cavo elettrico di alimentazione lungo 10 m in H07RNF

- *Cast-iron casing*
- *Cast-iron impeller*
- *Stainless steel AISI 304 motor shaft on the hydraulic side*
- *Double silicon carbide/ceramic carbon mechanical seal with oil barrier on pump side*
- *10 m electric cable of H07RNF*

MOTORE / MOTOR

- Motore ad induzione a 2 poli, 50 Hz in bagno d'olio, adatto per il servizio continuo
- Grado di protezione: IP68, isolamento in classe F
- Alimentazione monofase 230V: per il funzionamento è necessario prevedere un quadro elettrico completo di condensatore (da 35 μ F per la versione da HP 1,5; da 50 μ F per la versione da 2 HP)
- Alimentazione trifase 400V

- *2 poles induction motor, 50 Hz in oil bath, suitable for continuous duty*
- *IP68 protection, Class F insulation*
- *230V Single-phase feeding: to operate the pump a control board with capacitor must be used (35 μ F for the 1,5 HP version; 50 μ F for the 2 HP version)*
- *400V Three-phase feeding*

LIMITI DI IMPIEGO / OPERATING CONDITIONS

- Temperatura massima del liquido pompato: 40°C
- Profondità max di immersione 20 m
- Passaggio solidi: 10 mm

- *Maximum temperature of pumped liquid: 40°C*
- *Max immersion depth 20 m*
- *Solid passage: 10 mm*

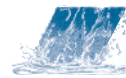

ELETTROPOMPE SOMMERSIBILI A GIRANTE APERTA
SUBMERSIBLE PUMPS WITH OPEN IMPELLER

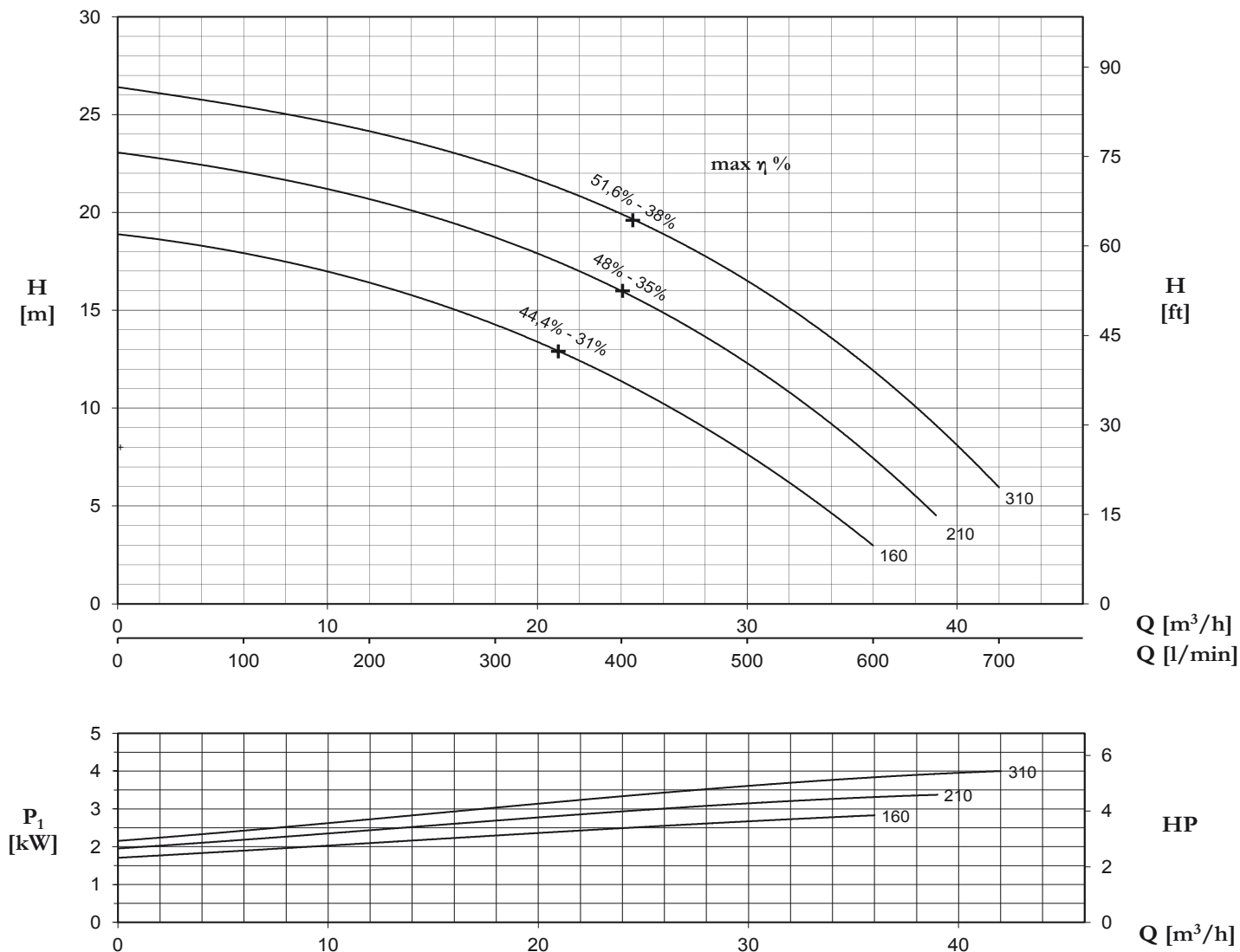

CARATTERISTICHE TECNICHE A 2900 GIRI / TECHNICAL PERFORMANCE AT 2900 RPM

Modello Model		P2		A		Q (m³/h -l/min)									
						0	6	12	18	24	30	36	39	42	
1~	3~	(HP)	(kW)	1x230V	3x400V	0	100	200	300	400	500	600	650	700	
H (m)															
DC 160	DC 160T	1,5	1,1	13,8	4,8	18,9	17,9	16,4	14,3	11,4	7,6	3			
DC 210	DC 210T	2	1,5	16,5	5,9	23	22,2	20,7	18,6	15,9	12,5	7,4	4,5		
	DC 310T	3	2,2		6,9	26,4	25,4	24,2	22,4	19,9	16,4	12,1	9,1	5,9	

Passaggio Solidi
Free passage
10 mm



+ max η %: rendimento ideale massimo
e rispettivo rendimento totale

Maximum hydraulic efficiency
and respective total efficiency

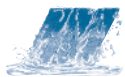
**DC**

COMPONENTI / COMPONENTS	MATERIALI / MATERIALS
Corpo motore, parte idraulica <i>Motor housing, hydraulic part</i>	Ghisa grigia <i>Grey cast Iron</i>
Motore elettrico <i>Electric motor</i>	Asincrono, a bagno d'olio <i>Asynchronous type, oil immersed</i>
Albero (lato pompa) <i>Shaft (pump side)</i>	Acciaio inossidabile <i>Stainless Steel</i>
Tenuta meccanica lato motore <i>Motor side mechanical seal</i>	Ceramica Carbone <i>Carbon - Ceramic</i>
Tenuta meccanica lato pompa <i>Pump side mechanical seal</i>	Carburo di Silicio - Carburo di Silicio <i>Silicon Carbide - Silicon Carbide</i>
Bulloni <i>Bolts</i>	Acciaio inossidabile A2 <i>A2 Stainless Steel</i>
Supporto piede <i>Foot support</i>	Ferro zincato <i>Galvanized Iron</i>
Guarnizioni (O-Ring) <i>Gaskets (O-Rings)</i>	Gomma NBR <i>NBR Rubber</i>

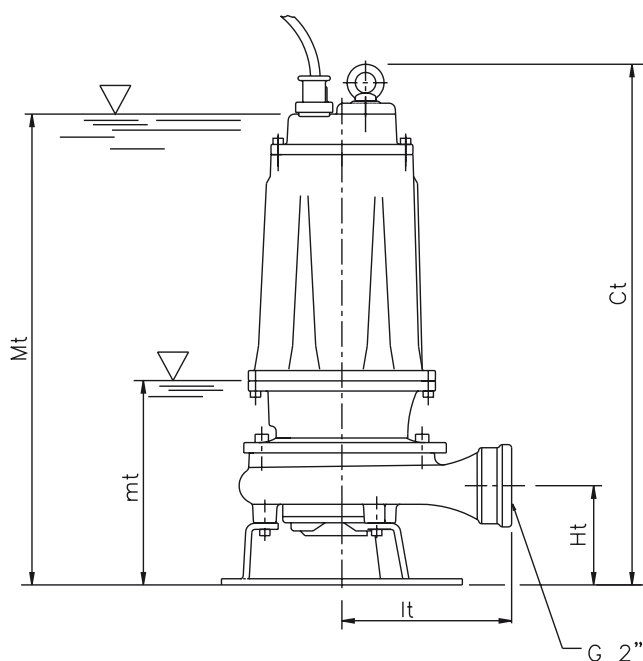
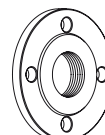
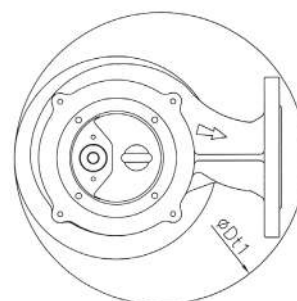
Flangia
CounterflangeLIBERA
MOBILE INSTALLATION

mt: livello minimo di lavoro
 Mt: livello minimo di servizio continuo
mt: lowest working level
Mt: lowest level for continuous duty

MODELLO - MODEL	DIMENSIONI (MM) - DIMENSIONS (MM)						DNM	PESO - WEIGHT
	Ct	ØDt1	Ht	Lt	mt	Mt		kg
DC 160 - DC 160T	513	282	102	174	205	475	G 2"	35
DC 210 - DC 210T	513	282	102	174	205	475	G 2"	36
DC 310T	513	282	102	174	205	475	G 2"	27

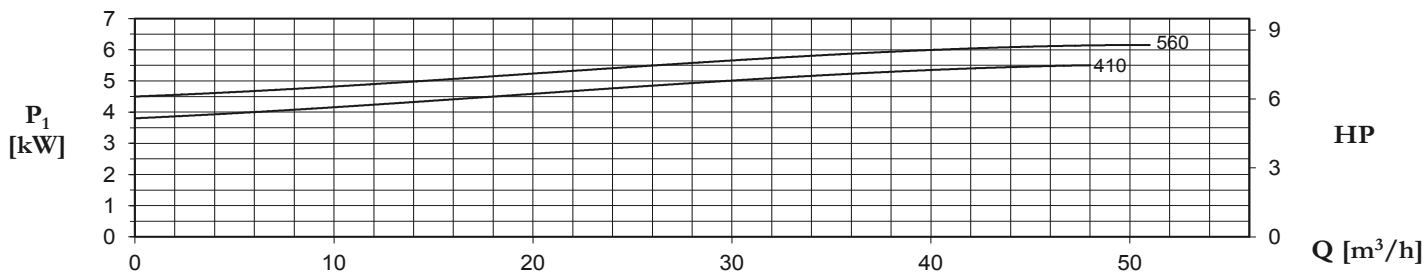
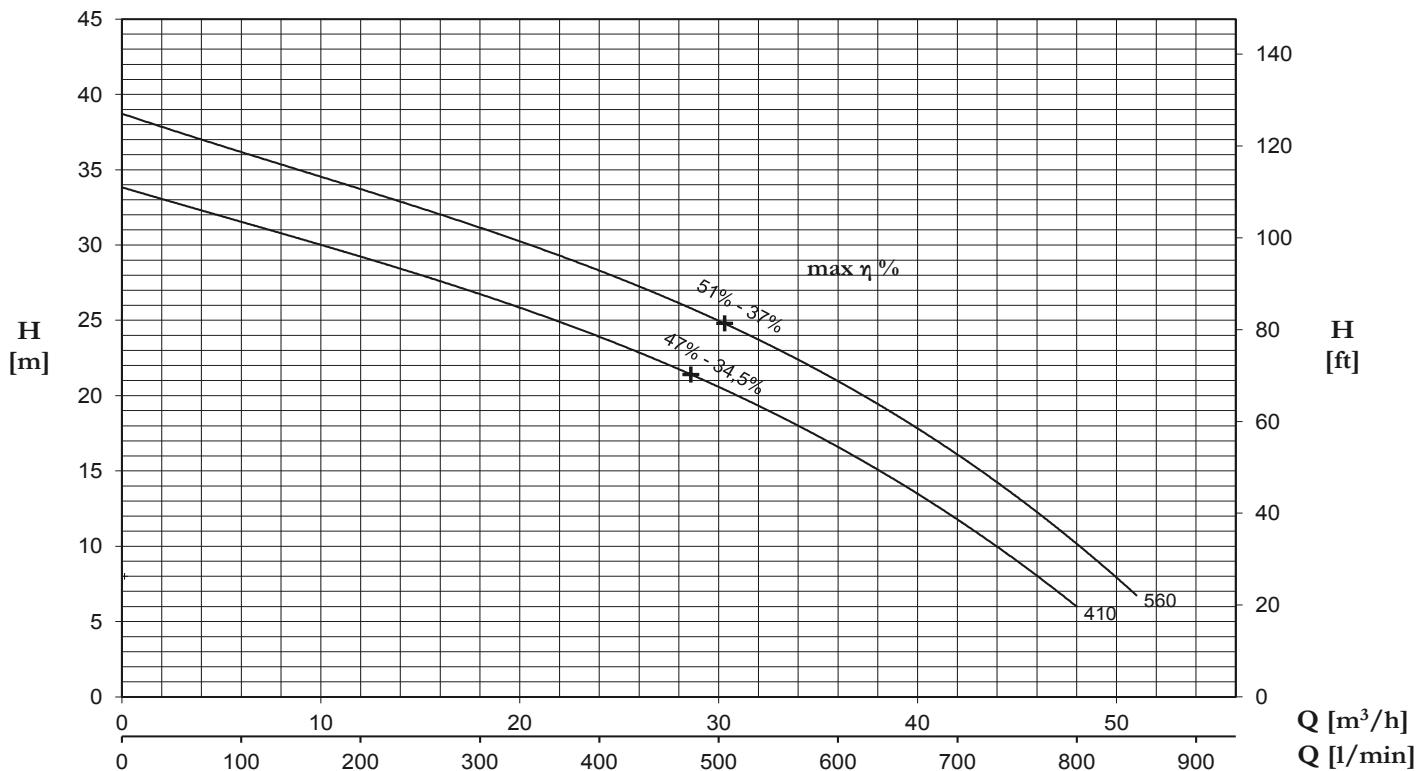
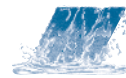

CARATTERISTICHE TECNICHE A 2900 GIRI / TECHNICAL PERFORMANCE AT 2900 RPM

Modello Model	P2		A	Q (m³/h -l/min)										
				0	6	12	18	24	30	36	42	48	51	
3~	(HP)	(kW)	3x400V	0	100	200	300	400	500	600	700	800	850	
				H (m)										
DC 410T	4	3	8,9	33,8	31,6	29,2	26,8	23,9	20,5	16,5	12,0	5,9		
DC 560T	5,5	4	10,7	38,7	36,1	33,9	31,2	28,3	24,7	20,9	16,3	10,4	6,5	

Passaggio Solidi
Free passage
10 mm



+ max η %: rendimento ideale massimo e rispettivo rendimento totale

Maximum hydraulic efficiency and respective total efficiency

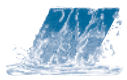

DC

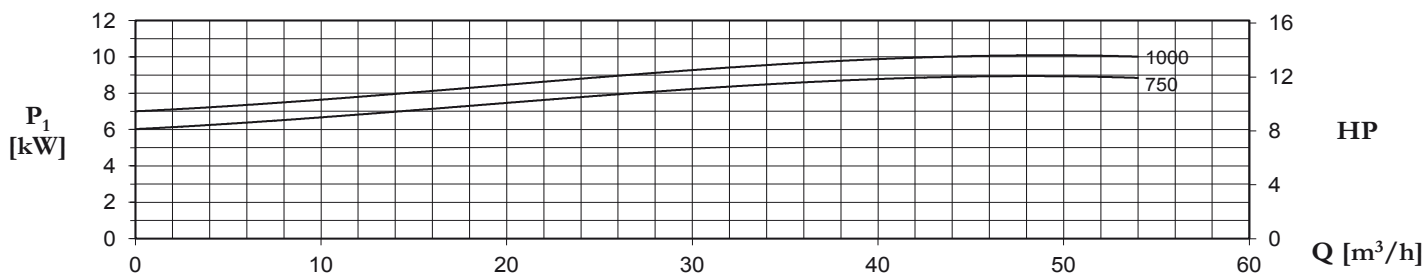
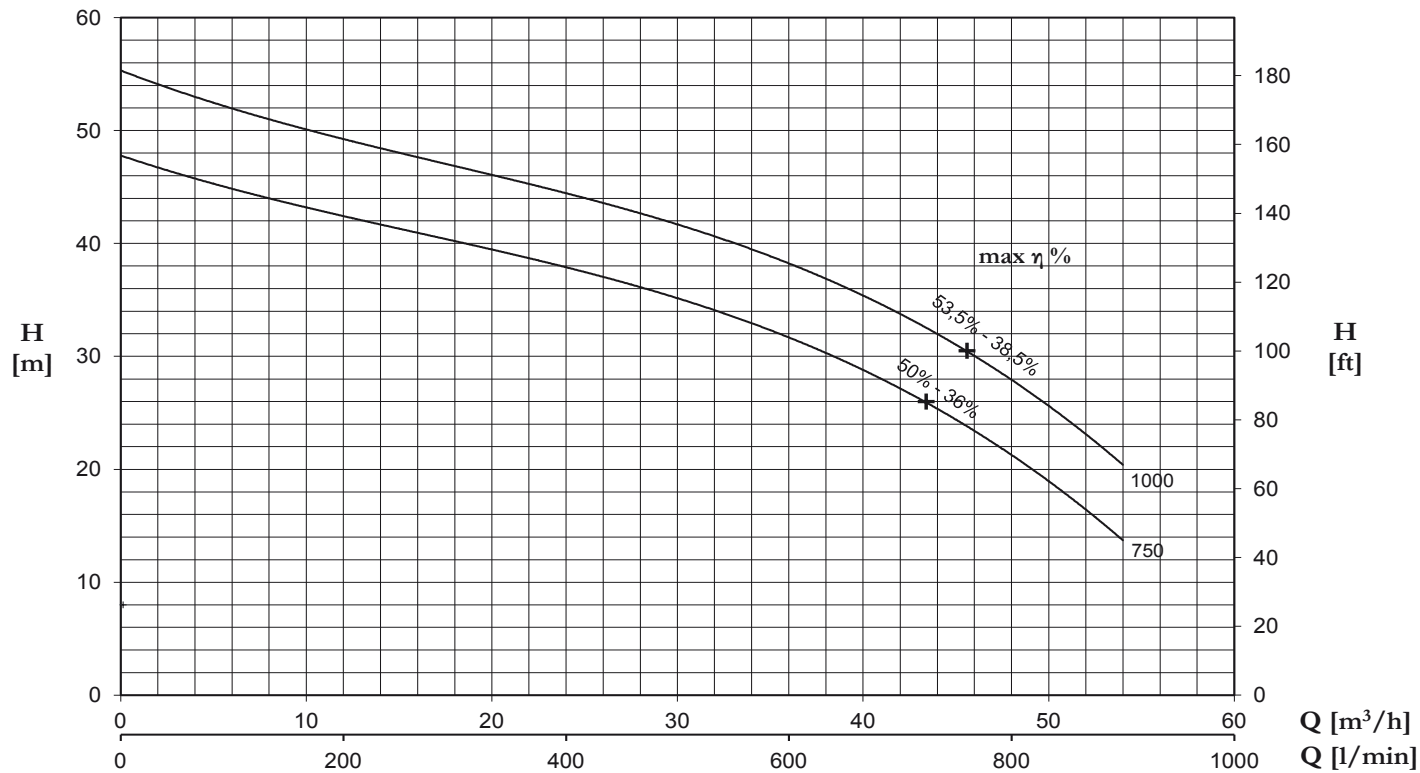

CARATTERISTICHE TECNICHE A 2900 GIRI / TECHNICAL PERFORMANCE AT 2900 RPM

Modello Model	P2		A	Q (m³/h -l/min)									
				0	12	18	24	30	36	42	48	54	
3~	(HP)	(kW)	3x400V	0	200	300	400	500	600	700	800	900	
				H (m)									
DC 750T	7,5	5,5	15,3	47,6	42,9	40,4	37,7	34,7	31,2	27,4	22,3	13,1	
DC 1000T	10	7,5	17,5	55,1	49,8	47,1	44,2	41,1	37,8	34	29,1	19,7	

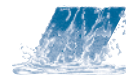

ELETTROPOMPE SOMMERSIBILI A GIRANTE APERTA
SUBMERSIBLE PUMPS WITH OPEN IMPELLER

COMPONENTI / COMPONENTS	MATERIALI / MATERIALS
Corpo motore, parte idraulica <i>Motor housing, hydraulic part</i>	Ghisa grigia <i>Grey cast Iron</i>
Motore elettrico <i>Electric motor</i>	Asincrono, a bagno d'olio <i>Asynchronous type, oil immersed</i>
Albero (lato pompa) <i>Shaft (pump side)</i>	Acciaio inossidabile <i>Stainless Steel</i>
Tenuta meccanica lato motore <i>Motor side mechanical seal</i>	Ceramica Carbone <i>Carbon - Ceramic</i>
Tenuta meccanica lato pompa <i>Pump side mechanical seal</i>	Carburo di Silicio - Carburo di Silicio <i>Silicon Carbide - Silicon Carbide</i>
Bulloni <i>Bolts</i>	Acciaio inossidabile A2 <i>A2 Stainless Steel</i>
Supporto piede <i>Foot support</i>	Ferro zincato <i>Galvanized Iron</i>
Guarnizioni (O-Ring) <i>Gaskets (O-Rings)</i>	Gomma NBR <i>NBR Rubber</i>

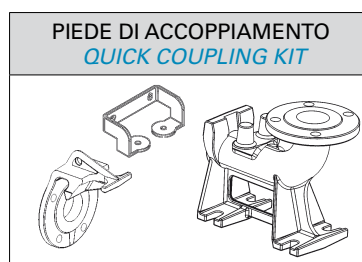

Flangia
Counterflange

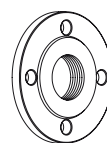

LIBERA - *MOBILE INSTALLATION*
DCT 410 - 1000

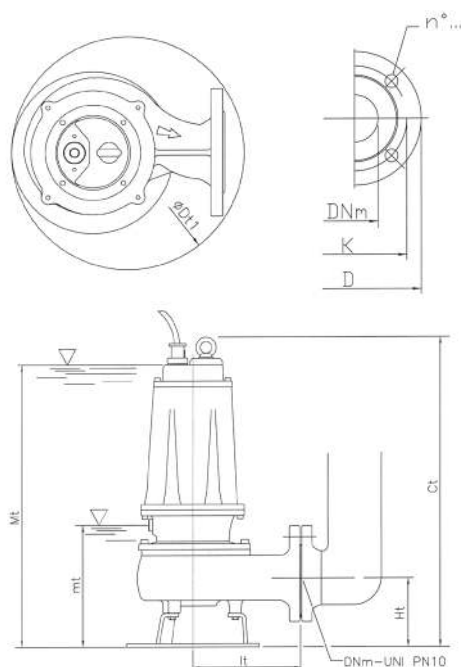

INSTALLAZIONE CON KIT PIEDE ACCOPPIAMENTO
FIXED INSTALLATION WITH QUICK COUPLING KIT
DCT 410 - 1000 / P

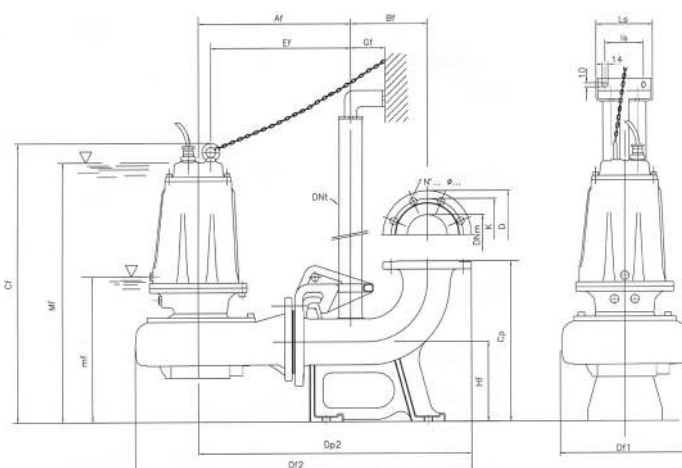

mt: livello minimo di lavoro
Mt: livello minimo di servizio continuo
mt: lowest working level
Mt: lowest level for continuous duty

MODELLO - MODEL	DIMENSIONI (MM) - DIMENSIONS (MM)						FLANGE - UNI PN10				PESO - WEIGHT
	Ct	ØDt1	Ht	It	mt	Mt	DNm	K	D	n°...Ø...	kg
DC 410 T	595	324	112	187	263	550	50	125	165	4...18...	56
DC 560 T	595	324	112	187	263	550	50	125	165	4...18...	64
DC 750 T	680	375	160	250	280	630	65	145	185	4...18...	92
DC 1000 T	680	375	160	250	280	630	65	145	185	4...18...	96

MODELLO - MODEL	DIMENSIONI (MM) - DIMENSIONS (MM)													FLANGE - UNI PN10						
	Af	Bf	Cf	Cp	Df1	Df2	Dp2	DNt	Ef	Gf	Hf	I1	I2	Is	Ls	mf	Mf	DNm	K	D
DC 410 / PT	535	145	614	260	237	654	535	1"1/4	266	55	130	200	200	95	140	290	566	50	125	165
DC 560 / PT	535	145	614	260	237	654	535	1"1/4	266	55	130	200	200	95	140	290	566	50	125	165
DC 750 / PT	566	145	656	260	279	724	566	1"1/4	294	55	130	200	200	95	140	290	600	65	600	185
DC 1000 / PT	566	145	656	260	279	724	566	1"1/4	294	55	190	250	200	95	140	290	600	65	600	185